



PROFAX[®]

WTS-44 Adjustable Welding Torch Stand

Features:

General:

- Manually adjustable
- Extruded aluminum construction
- Lockable casters included for easy movement
- Unit weight: 70 lbs.

Mast / Column:

- Hand wheel adjustment via worm gear drive. Provides anti-fall protection
- 46" Vertical travel
- 60" Max. clearance under boom

Boom:

- Hand wheel adjustment
- 46" Horizontal travel
- 50" of reach
- Dual swivel adjustable V-block torch mount included
- Drilled and tapped plate for PROFAX WCS-222 (optional)
- 25 lb. maximum load capacity

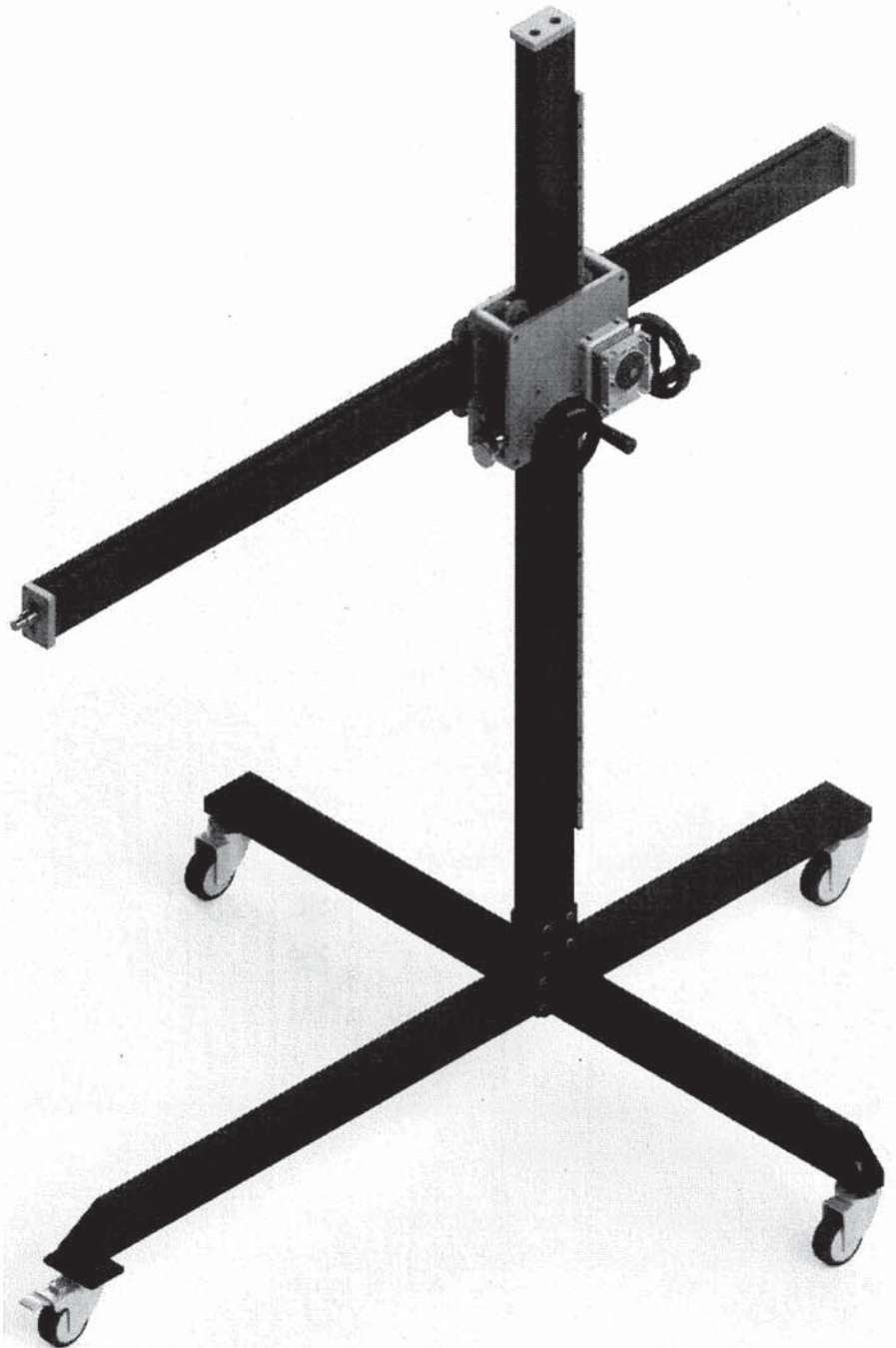

Introduction:

The WTS-44 freestanding torch support is a compact easy to use system designed to maintain constant torch-to-work distance. Rack and pinion movement on lightweight aluminum extrusions provides smooth and effortless positioning of the welding gun or cutting torch.

Technical Data:

Total Vertical Adjustment:	46"
Maximum under boom height:	60"
Total Horizontal Adjustment:	46"
Maximum Reach:	50"
Net Weight:	70 lbs.
Maximum End Boom Capacity:	25 lbs.

Assembly

Your WTS-44 is packaged in a two compartment wood crate and will require some assembly for use.

The hardware and components will include:

- 1ea Base main leg (A)
- 2ea Base side leg (B)
- 2ea Base shim (C)
- 1ea Upright extrusion (D)
- 1ea Roller and gear carriage (E)
- 2ea Stop plate (F & H)
- 1ea Boom extrusion (G)
- 1ea Boom torch mounting plate (I)
- 8ea M8 x 16mm socket head bolts
- 8ea M6 x 65mm socket head bolts
- 8ea M6 lock nuts
- 16ea M6 flat washers

You will need a 5mm & 6mm Allen wrench and a 10mm combination wrench or socket. Follow the procedure and drawing below for assembly.

1. Install 2ea 8mm bolts through the bottom of main leg (A) into upright (D) but do not fully tighten at this time. Ensure gear rack on upright is facing shorter side of main leg.

2. Insert 8ea M6 bolts with flat washers through side leg (B). Install shim (C) over lower 4 bolts. Install to main leg (A) and upright (D) then follow with other shim (C) and other side leg (B). Now install M6 flat washers and nuts. Ensure shims are only on lower 4 bolts going through main leg (A).
3. First tighten M8 bolts installed in step one followed by the M6 bolts in step 2.
4. Orient carriage assembly (E) over upright (D) with worm gear reducer over gear rack on upright (D). Once the carriage (E) has engaged the gear rack it will be necessary to turn the worm gear reducer hand wheel to lower the carriage assembly.
5. Install top stop plate (F) using supplied M8 bolts and tighten.
6. Slide boom (G) through rollers on carriage (E) with gear rack on bottom and facing out. Boom (G) must be inserted with all 4 rollers in the slots or the extrusion could be damaged.
7. Install end plate (H) with 8mm bolts on end of boom (G) with shorter main leg.
8. Install torch mounting plate (I) to end of boom (G) that has longer main leg.

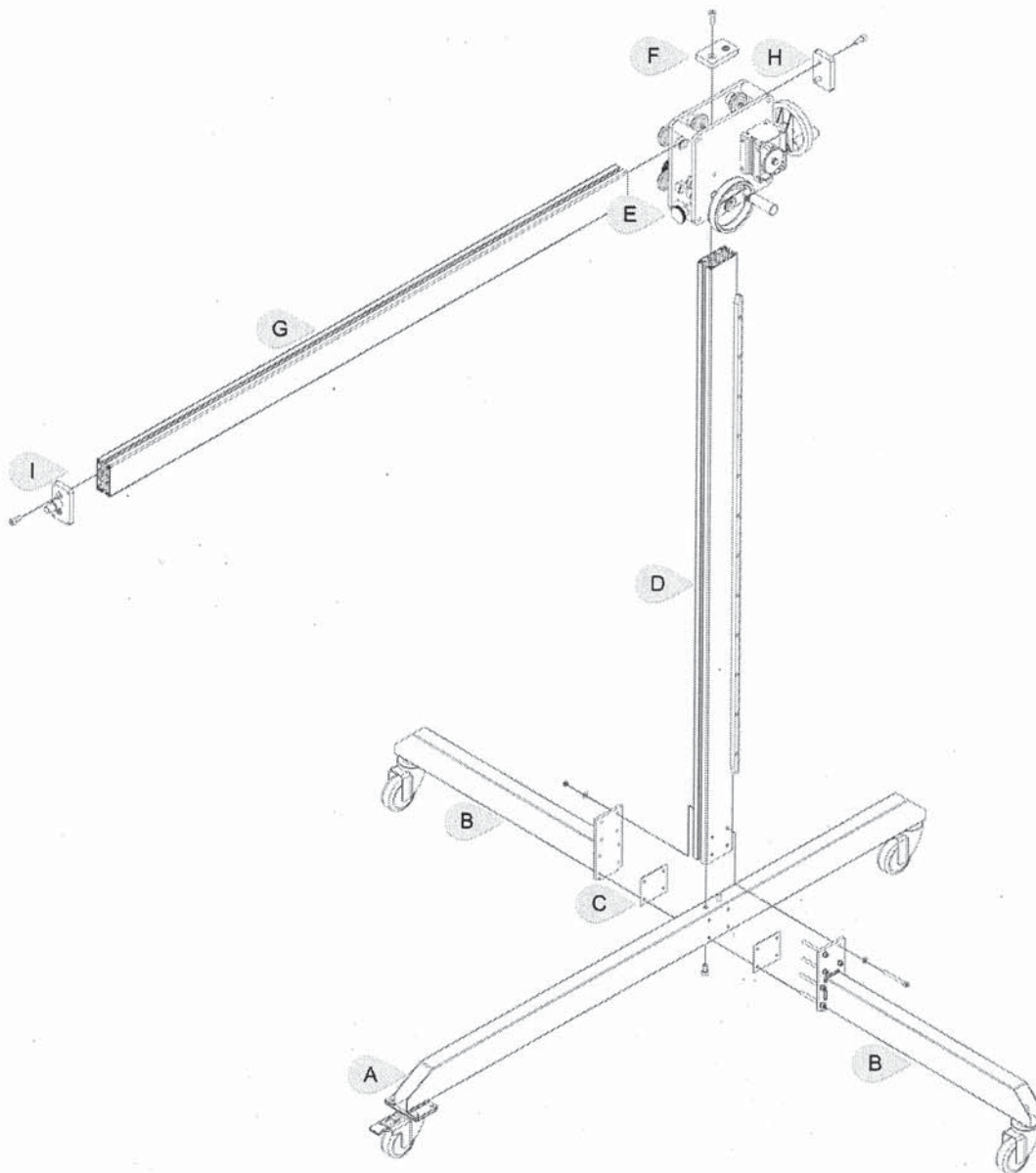

Wheel Adjustment

The WTS-44 is equipped with wheels that ride along a groove in the aluminum extrusion. Each wheel has an eccentric bushing for maintaining proper wheel to groove clearance. The WTS-44 is shipped with the clearance pre-adjusted but should be inspected prior to each use. The wheels need adjustment only if the assembly has excessive play. The wheels should be snug, but not prohibit movement along the path of travel.

To adjust the wheels, loosen the securing bolt until the adjustable bushing can be rotated. Correct the wheel alignment by rotating the adjustable bushing. Once adjusted, hold the adjustable bushing while tightening the securing bolt. Recheck alignment.

Maintenance

It is recommended that the WTS-44 be inspected daily. Inspect the gear rack, gears, wheels and wheel grooves. Remove all dirt and grease. Inspect wheels and grooves for nicks and replace as needed. Check wheel alignment and adjust as needed. Do not apply lubrication to gears or wheels as this will attract dirt and contaminants. The vertical lift uses a worm gear reducer. The gear oil in this reducer should be inspected every six months or sooner if a leak is detected.