

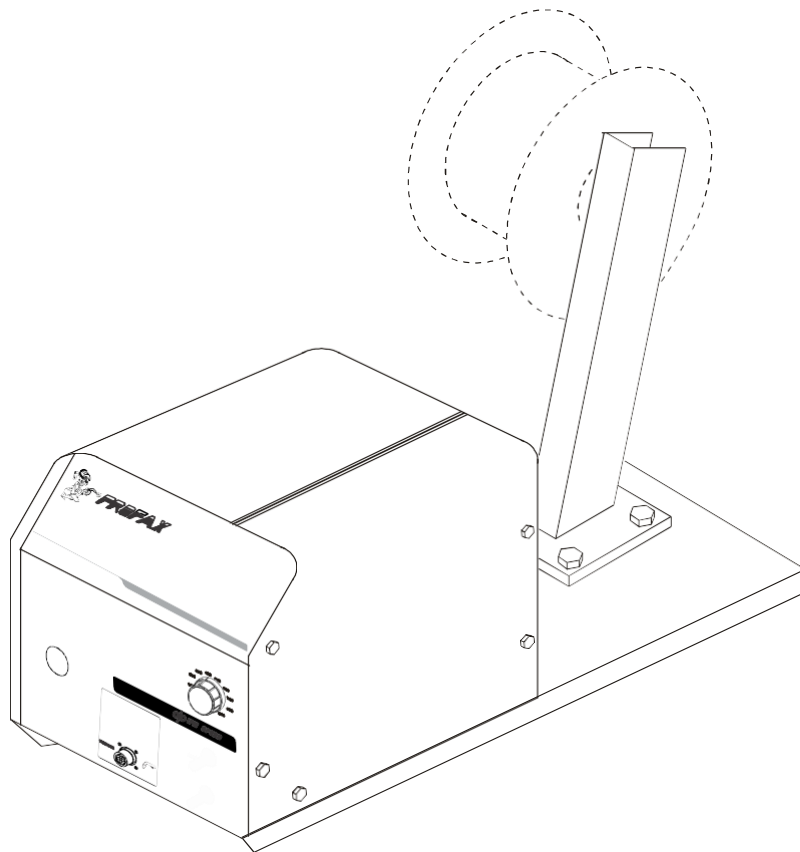

PROFAX[®]

OWNER'S MANUAL

PX20-TIG TIG COLD WIRE FEED SYSTEM



Visit our website at:
www.profax-lenco.com



GIVE THIS MANUAL TO THE OPERATOR

TABLE OF CONTENTS

ARC WELDING SAFETY PRECAUTIONS	i
SECTION 1 -- SAFETY INFORMATION	1
SECTION 2 -- SPECIFICATIONS	1
SECTION 3 -- INSTALLATION	1
3 - 1. Wirefeeder	1
3 - 2. Feed Pen connections	2
3 - 3. Rear Panel	2
3 - 4. Wire spool installation	3
3 - 5. Welding wire installation	3
SECTION 4 -- OPERATION	5
SECTION 5 -- MAINTENANCE AND TROUBLESHOOTING	6
5 - 1. Routine Maintenance	6
5 - 2. Troubleshooting	6
5 - 3. Overload protection	6
WARRANTY POLICY	

ARC WELDING SAFETY PRECAUTIONS



WARNING **ARC WELDING can be hazardous.**

PROTECT YOURSELF AND OTHERS FROM POSSIBLE SERIOUS INJURY OR DEATH. KEEP CHILDREN AWAY. PACEMAKER WEARERS KEEP AWAY UNTIL CONSULTING YOUR DOCTOR.

In welding, as in most jobs, exposure to certain hazards occurs. Welding is safe when precautions are taken. The safety information given below is only a summary of the more complete safety information that will be found in the Safety Standards. Read and follow all Safety Standards.

HAVE ALL INSTALLATION, OPERATION, MAINTENANCE, AND REPAIR WORK PERFORMED ONLY BY QUALIFIED PEOPLE.



ELECTRIC SHOCK can kill.

Touching live electrical parts can cause fatal shocks or severe burns. The electrode and work circuit is electrically live whenever the output is on. The input power circuit and machine internal circuits are also live when power is on. In semiautomatic or automatic wire welding, the wire, wire reel, drive roll housing, and all metal parts touching the welding wire are electrically live. Incorrectly installed or improperly grounded equipment is a hazard.

- 1.- Do not touch live electrical parts.
- 2.- Wear dry, hole-free insulating gloves and body protection.
- 3.- Insulate yourself from work and ground using dry insulating mats or covers.
- 4.- Disconnect input power or stop engine before installing or servicing this equipment.
- 5.- Properly install and ground this equipment according to this owner's manual and national, state, and local codes.

- 6.- Turn off all equipment when not in use.
- 7.- Do not use worn, damaged, undersized, or poorly spliced cables.
- 8.- Do not wrap cables around your body.
- 9.- Ground the workpiece to a good electrical (earth) ground.
- 10.- Do not touch electrode while in contact with the work (ground) circuit.
- 11.- Use only well-maintained equipment. Repair or replace damaged parts at once.
- 12.- Wear a safety harness to prevent falling if working above floor level.
- 13.- Keep all panels and cover securely in place.

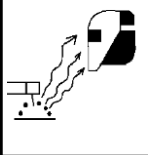

ARC RAYS can burn eyes and skin; NOISE can damage hearing.

Arc rays from the welding process produce intense heat and strong ultraviolet rays that can burn eyes and skin. Noise from some processes can damage hearing.

- 1.- Wear a welding helmet fitted with a proper shade of filter (see ANSIZ49.1 listed in Safety Standards) to protect your face

- and eyes when welding or watching.
- 2.- Wear approved safety glasses. Side shields recommended.
- 3.- Use protective screens or barriers to protect others from flash and glare; warn others not to watch the arc.
- 4.- Wear protective clothing made from durable, flame-resistant material (wool and leather) and foot protection.
- 5.- Use approved ear plugs or ear muffs if noise level is high.



FUMES AND GASES can be hazardous to your health.

Welding produces fumes and gases. Breathing these fumes and gases can be hazardous to your health.

- 1.- Keep your head out of the fumes. Do not breathe the fumes.
- 2.- If inside, ventilate the area and / or use exhaust at the arc to remove welding fumes and gases.
- 3.- If ventilation is poor, use an approved air-supplied respirator.
- 4.- Read the Material Safety Data Sheets (MSDSs) and the manufacturer's instruction for metal, consumables, coatings, and cleaners.

- 5.- Work in a confined space only if it is well ventilated, or while wearing an air-supplied respirator. Shielding gases used for welding can displace air causing injury or death. Be sure the breathing air is safe.
- 6.- Do not weld in locations near degreasing, cleaning, or spraying operations. The heat and rays of the arc can react with vapors to form highly toxic and irritating gases.
- 7.- Do not weld on coated metals, such as galvanized, lead, or cadmium plated steel, unless the coating is removed from the weld area, the area is well ventilated, and if necessary, while wearing an air-supplied respirator. The coatings and any metals containing these elements can give off toxic fumes if welded.





WELDING can cause fire or explosion.

Sparks and spatter fly off from the welding arc. The flying sparks and hot metal, weld spatter, hot workpiece, and hot equipment can cause fires and burns. Accidental contact of electrode or welding wire to metal objects can cause sparks, overheating, or fire.

- 1.- Protect yourself and others from flying sparks and hot metal.
- 2.- Do not weld where flying sparks can strike flammable material.
- 3.- Remove all flammables within 35ft (10.7 m) of the welding arc. If this is not possible, tightly cover them with approved covers.

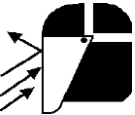
- 4.- Be alert that welding sparks and hot materials from welding can easily go through small cracks and openings to adjacent areas.
- 5.- Watch for fire, and keep a fire extinguisher nearby.
- 6.- Be aware that welding on a ceiling, floor, bulkhead, or partition can cause fire on the hidden side.
- 7.- Do not weld on closed containers such as tanks or drums.
- 8.- Connect work cable to the work as close to the welding areas as practical to prevent welding current from traveling long, possibly unknown paths and causing electric shock and fire hazards.
- 9.- Do not use welder to thaw frozen pipes.
- 10.- Remove stick electrode from holder or cut off welding wire at contact tip when not in use.
- 11.- Wear oil-free protective garments such as leather gloves, heavy shirt, cuff less trousers, high shoes, and a cap.

	<p>FLYING SPARK AND HOT METAL can cause injury</p> <p>Chipping and grinding cause flying metal . As welds cool, they can throw off slag.</p>	<ol style="list-style-type: none"> 1.- Wear approved face shield or safety goggles. Side shields recommended. 2.- Wear proper body protection to protect skin.
--	---	--

	<p>CYLINDERS can explode if damaged.</p> <p>Shielding gas cylinders contain gas under high pressure. If damaged, a cylinder can explode. Since gas cylinders are normally part of the welding process, be sure to treat them carefully.</p>	<ol style="list-style-type: none"> 4.- Never allow a welding electrode to touch any cylinder. 5.- Use only correct shielding gas cylinders, regulators, hoses, and fittings designed for the specific application; maintain them and associated parts in good condition. 6.- Turn face away from valve outlet when opening cylinder valve. 7.- Keep protective cap in place over valve except when cylinder is in use or connected for use. 8.- Read and follow instructions on compressed gas cylinders, associated equipment, and CGA publication P-1 listed in Safety Standards.
<ol style="list-style-type: none"> 1.- Protect compressed gas cylinders from excessive heat, mechanical shocks, and arcs. 2.- Install and secure cylinders in an upright position by chaining them to a stationary support or equipment cylinder rack to prevent falling or tipping. 3.- Keep cylinders away from any welding or other electrical circuits. 		

	<p>WARNING ENGINES can be hazardous.</p>
--	---

	<p>ENGINE EXHAUST GASES can kill.</p> <p>Engines produce harmful exhaust gases.</p>	<ol style="list-style-type: none"> 1.- Use equipment outside in open, well-ventilated areas. 2.- If used in a closed area, vent engine exhaust outside and away from any building air intakes.
--	--	--

	<p>ENGINE FUEL can cause fire or explosion.</p> <p>Engine fuel is highly flammable.</p>	<ol style="list-style-type: none"> 1.- Stop engine before checking or adding fuel. 2.- Do not add fuel while smoking or if unit is near any sparks or open flames. 3.- Allw engine to cool before fueling. If possible, check and add fuel to cold engine before beginning job. 4.- Do not overfill tank - allow room for fuel to expand. 5.- Do not spill fuel. If fuel is spilled, clean up before starting engine.
---	--	--

	<p>MOVING PARTS can cause injury.</p> <p>Moving parts, such as fans, rotors, and belts can cut fingers and hands and catch loose clothing.</p>	<ol style="list-style-type: none"> 1.- Keep all doors, panels, covers, and guards closed and securely in place. 2.- Stop engine before installing or connecting unit. 3.- Have only qualified people remove guards or covers for maintenance and troubleshooting as necessary. 4.- To prevent accidental starting during servicing, disconnect negative (-) battery cable from battery. 5.- Keep hands, hair, loose clothing, and tools away from moving parts. 6.- Reinstall panels or guards and close doors when servicing is finished and before starting engine.
--	---	---

	<p>SPARKS can cause BATTERY GASES TO EXPLODE; BATTERY ACID can burn eyes and skin.</p> <p>Batteries contain acid and generate explosive gases.</p>	<ol style="list-style-type: none"> 1.- Always wear a face shield when working on a battery. 2.- Stop engine before disconnecting or connecting battery cables. 3.- Do not allow tools to cause sparks when working on a battery. 4.- Do not use welder to charge batteries or jump start vehicles. 5.- Observe correct polarity (+ and -) on batteries.
--	---	--

	<p>STEAM AND PRESSURIZED HOT COOLANT can burn face, eyes, and skin.</p> <p>The coolant in the radiator can be very hot and under pressure.</p>	<ol style="list-style-type: none"> 1.- Do not remove radiator cap when engine is hot. Allow engine to cool. 2.- Wear gloves and put a rag over cap area when removing cap. 3.- Allow pressure to escape before completely removing cap.
--	---	--

SECTION 1 SAFETY SIGNAL WORDS

The following safety alert symbol and signal words are used throughout this manual to call attention to and identify different levels of hazard and special instructions.

 **WARNING** WARNING statements identify procedures or practices which must be followed to avoid serious personal injury or loss of life.

 **CAUTION** CAUTION statements identify procedures or practices which must be followed to avoid minor personal injury or damage to this equipment.

IMPORTANT: Statements identify special instructions necessary for the most efficient operation of this equipment.



SECTION 2 SPECIFICATIONS

TABLE 2-1 TECHNICAL SPECIFICATIONS

Specifications	Description
Input power:	Single phase, 115VAC, 3A, 50/60Hz.
Duty Cycle:	100% Duty cycle.
Wire feed speed range:	75 to 900 IPM (1.9 to 23 m/min)
Wire diameter range:	0.023 to 5/64" (0.6 to 2.0mm)
Input power cord:	10 Ft (3 M).
Overall dimensions:	Depth: 25-1/2" (648mm); Width: 11" (280mm); Height: 14" (356mm).
Weight:	Net: 36 lb. (16.5 Kg)

SECTION 3 INSTALLATION

3-1 WIRE FEEDER

 **WARNING**   **ELECTRIC SHOCK** can kill; **ARCING** can damage unit. **MOVING PARTS** can cause injury.

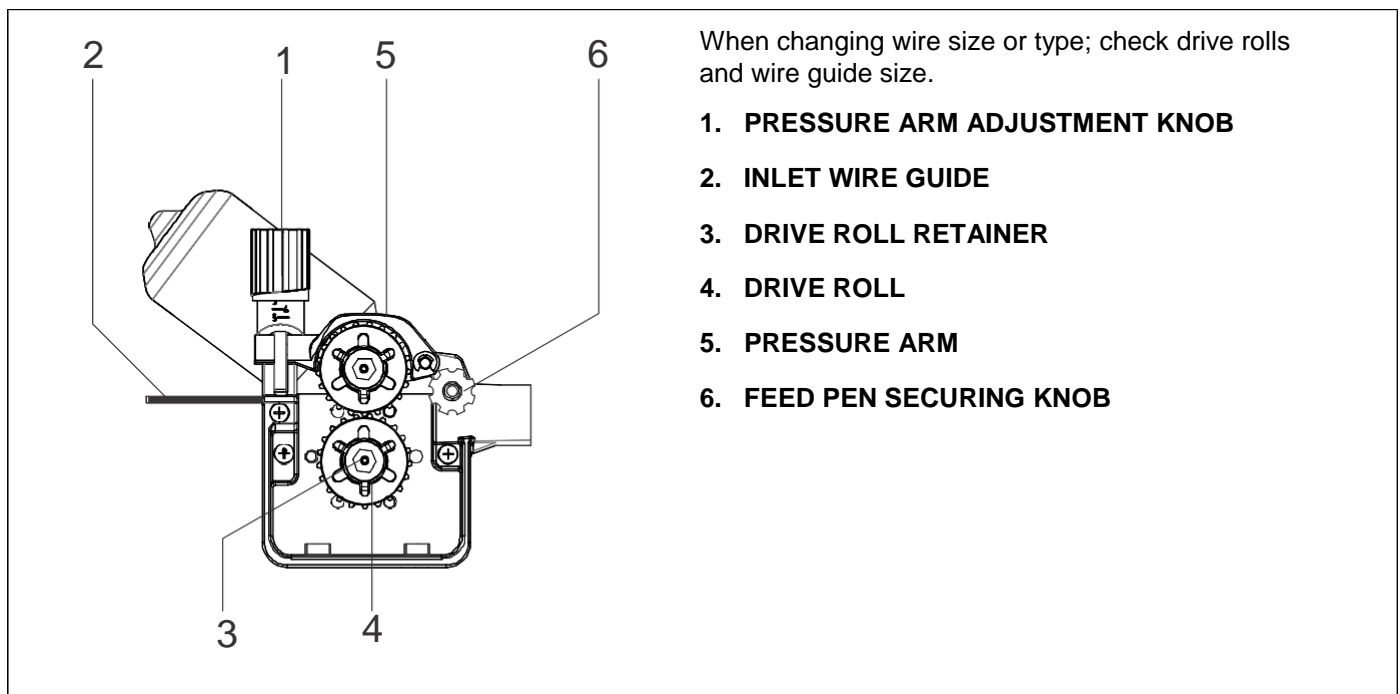

FIGURE 3-1 WIRE FEEDER

3-2 FEED PEN CONNECTIONS

	WARNING		ELECTRIC SHOCK can kill; MOVING PARTS can cause injury.
	<p>Turn off and disconnect wire feeder, open wire feeder door.</p> <ol style="list-style-type: none">1. ACCESS HOLE FOR FEED PEN CONNECTION.2. FEED PEN INLET GUIDE. Loosen securing knob and insert feed pen into block fully. Tighten securing knob.3. TRIGGER PLUG.4. TRIGGER RECEPTACLE. Insert plug into receptacle and tighten threaded collar. <p>Close and latch door.</p>		

FIGURE 3-2 FEED PEN AND TRIGGER LEAD CONNECTIONS

3-3 REAR PANEL

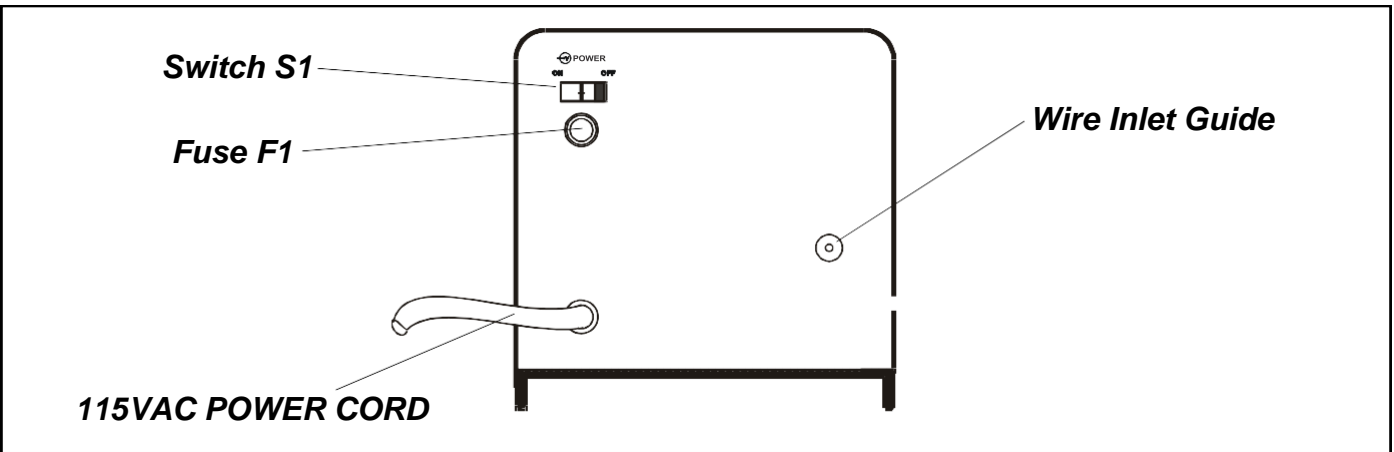

FIGURE 3-3 REAR PANEL UNIT

3-4 WIRE SPOOL INSTALLATION

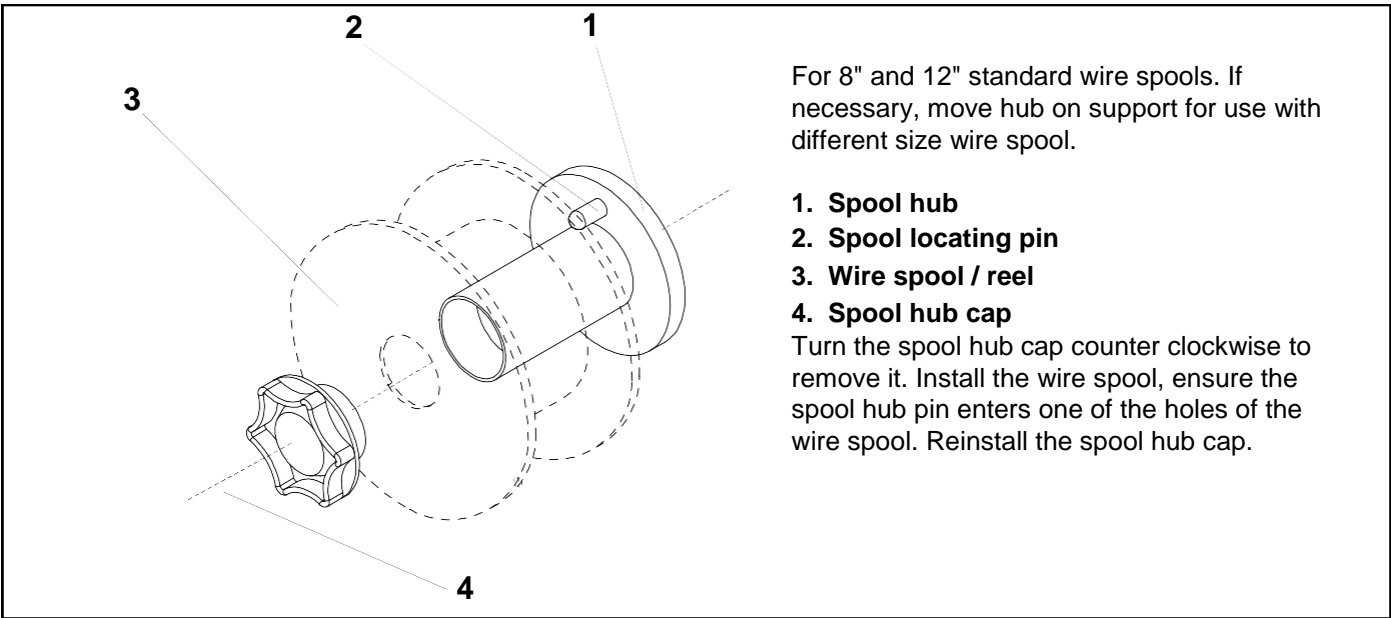

FIGURE 3-4 WIRE SPOOL INSTALLATION.

3-5 WELDING WIRE INSTALLATION

WARNING



SEE SAFETY PRECAUTIONS AT BEGINNING OF MANUAL FOR BASIC WELDING INFORMATION.

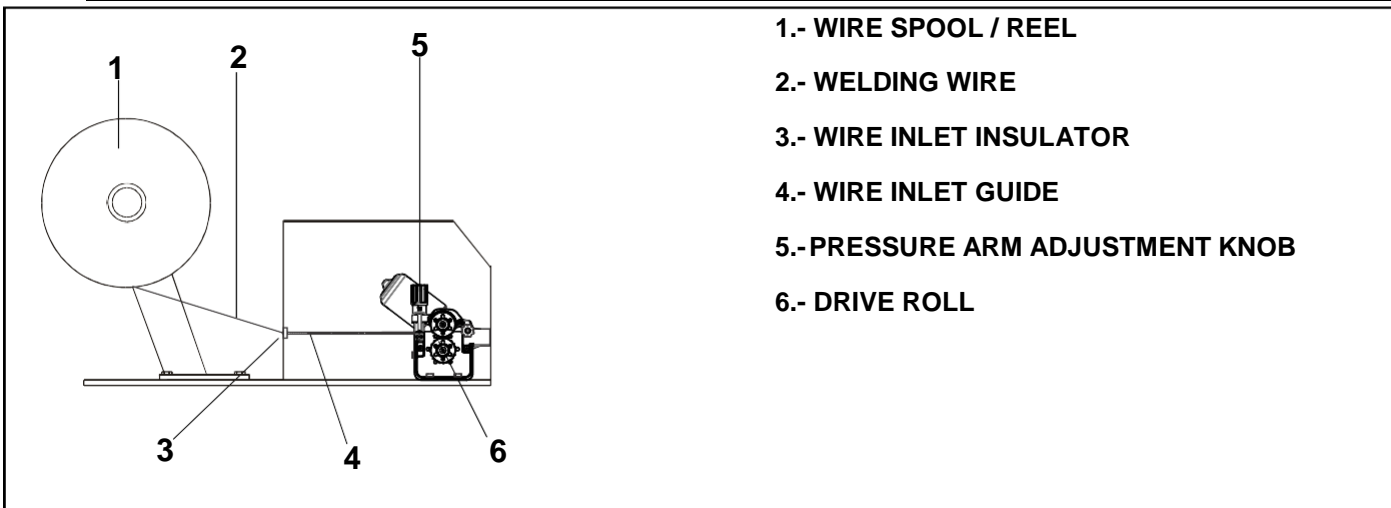



HOLD WIRE TIGHTLY TO PREVENT UNRAVELING

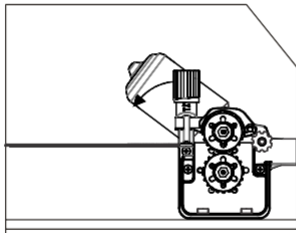

Open pressure arm assembly.

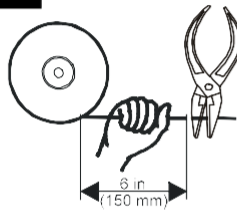

Hold wire tightly and cut off end.

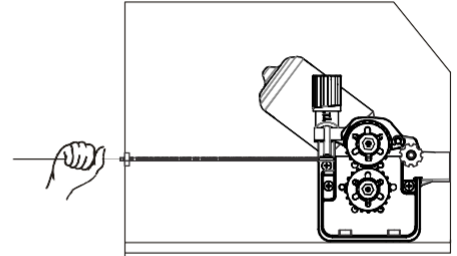

Feed wire through guide into feed pen. Continue to hold wire.

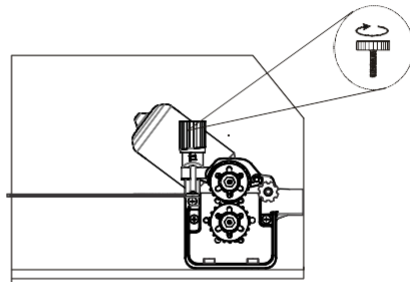

Close and latch pressure arm assembly.

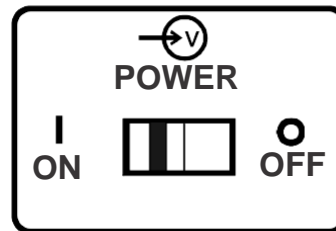

Turn on wire feeder.



To adjust drive roll pressure, press trigger to feed wire against wood surface and adjust knob so wire does not slip.

Cut off excess wire. Close and latch door.

SECTION 4 OPERATION

4-1 CONTROLS

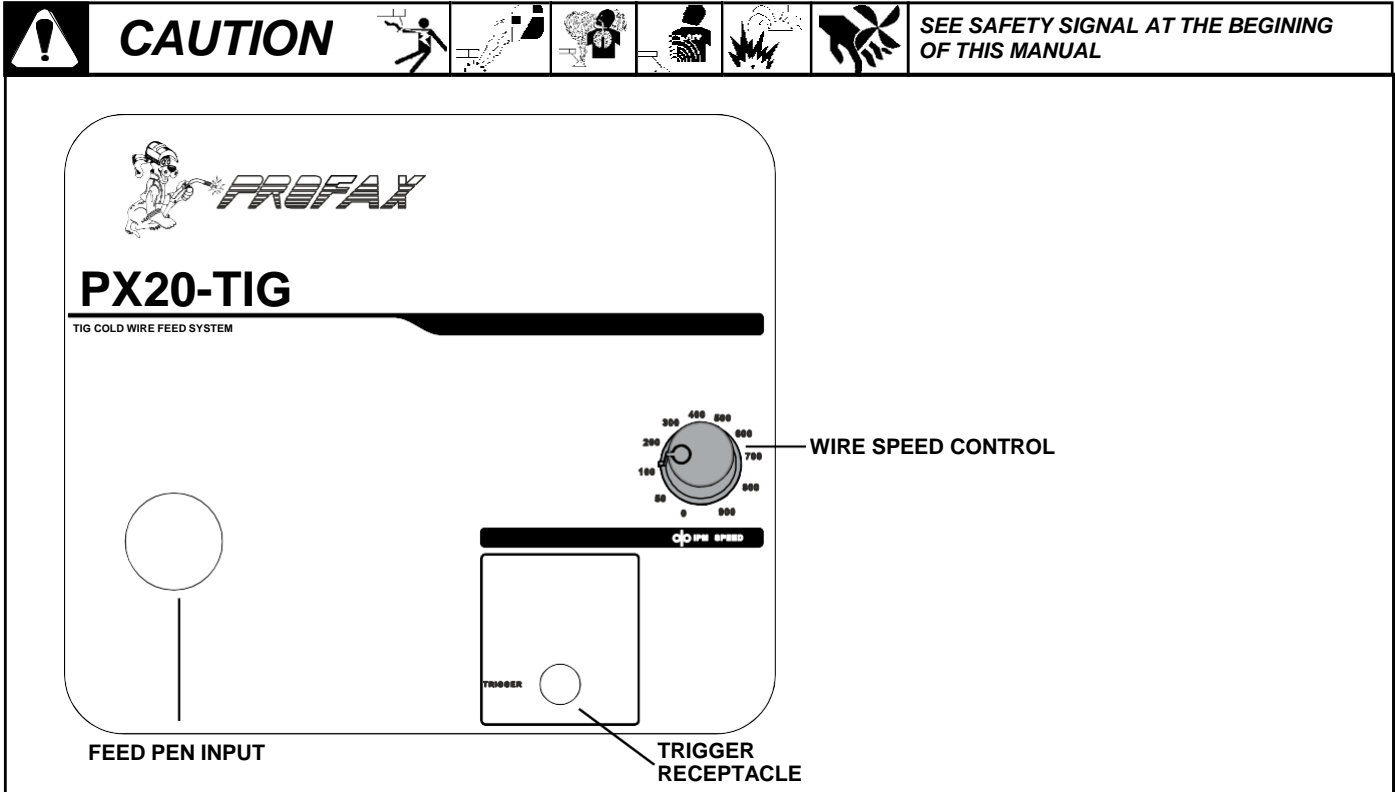

FIGURE 4-1 CONTROLS

Place the switch in **ON** position to turn wire feeder on.

Place the switch in **OFF** position to turn wire feeder off.

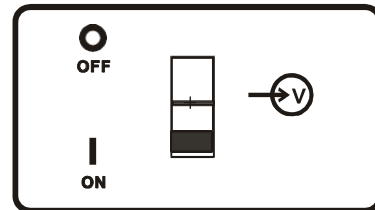

FIGURE 4-2 INPUT POWERSWITCH

1 - WIRE FEED SPEED CONTROL.

Use this control to set wire feed speed. Turn clockwise to increase speed. The numbers are a reference with respect to a maximum rated wire feed of 900ipm.

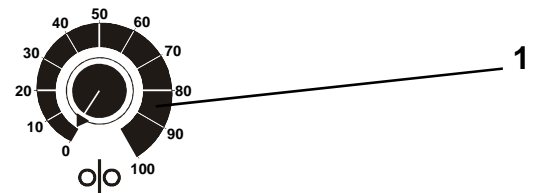

FIGURE 4-3 WIRE SPEED CONTROL

SECTION 5 MAINTENANCE AND TROUBLESHOOTING



5-1 ROUTINE MAINTENANCE

TIME	MAINTENANCE
3 MONTHS	Check all labels. Repair or replace any damaged cables and feed pen. Clean and tighten all weld cable connections. <i>More than normal use: (see 6 month entry)</i>
6 MONTHS	Clean drive rolls. Blow out or vacuum inside. Clean all rotating parts. <i>During heavy service, clean monthly.</i>

5-2 TROUBLESHOOTINGS

TROUBLE	PROBABLE CAUSE	REMEDY
No wire feed	Power switch is off on wire feeder.	Turn power switch on.
	F1 fuse open.	Replace F1 fuse.
	Connection at power receptacle.	Check and repair power connection.
	Feed pen trigger circuit.	Repair trigger, plug or wiring in feed pen.
	Motor or control board PC1.	Have authorized repair agent diagnose.
Erratic wire feed	Drive roll pressure or spool hub tension	Readjust drive roll pressure and hub tension.
	Drive rolls size.	Change to correct drive roll size.
	Worn or dirty drive rolls.	Clean or replace drive rolls.
	Weld spatter on tip.	Clean or replace tip.
	Dirty contact tip or liner.	Replace contact tip and liner.
Motor or control board PC1.	Have authorized repair agent diagnose.	

5-3 OVERLOAD PROTECTION

	WARNING		SEE SAFETY SIGNAL AT THE BEGINNING OF THIS MANUAL
---	----------------	---	---

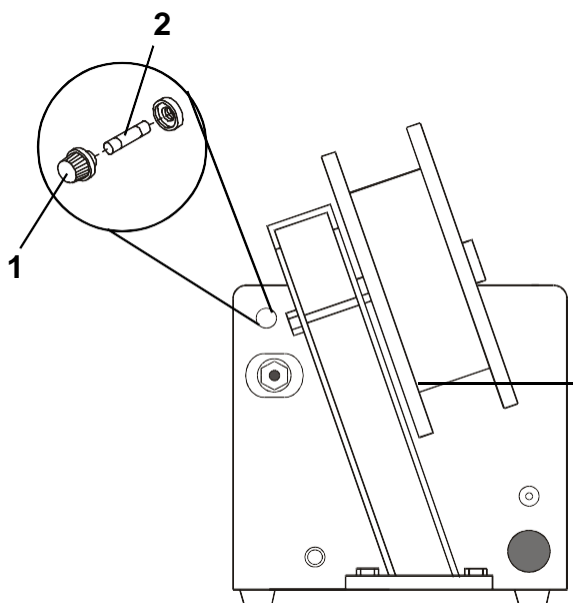

Turn off power source and disconnect wire feeder before proceeding.

Fuse F1 (10 amp) protects wire feeder from overload. Incorrect fuse size can damage unit. Be sure to select correct fuse size and capacity.

1 - FUSE COVER. Remove fuse cover.

2 - FUSE F1 (10 Amp)

FIGURE 5-1 OVERLOAD PROTECTION

PROFAX
1603 North Main Street Pearland Tx 77581 Phone: 281-485-6258

WARRANTY

LIMITED WARRANTY - Subject to the terms and conditions stated below, **PROFAX**, Pearland, TX warrants its products to be free from defects in material and/or workmanship at the time of delivery by **PROFAX**.

PROFAX will honor warranty claims on products proven to have failed from a defect in material and/or workmanship, for the appropriate time period as listed below, beginning from the distributor's date of sale to the original end user. For warranty to apply, products must be sold by the distributor **within 1 year** from the original date of sale to the distributor. Products will not be covered if damage is determined to be caused by misuse, neglect and/or abuse.

Consumable products manufactured by PROFAX	30 Days
Contactors, Meters, Fan Motors, Rheostats, Diodes, & Brushes.....	*OMW
Flux Cored Guns, MIG Guns & Spool Guns	90 Days
Arc Gouging Torches, Plasma Torches, TIG Torches & CO2 Heaters.....	90 Days
Control, Extensions, Interconnect and Adapter Cords, Plugs & Connectors.....	90 Days
Esab [®] , Lincoln [®] , Miller [®] , and PROFAX Drive Rolls.....	90 Days
Remote Fingertip, Hand and Foot Controls	90 Days
Slides, Oscillators, & Track Cutting Machine/Beveling Machine.....	90 Days
Turning Rolls, Welding Positioners, and Manipulators	1 Year
Spool Gun Controls, Pro II TIG, & Flowmeter/Regulator	1 Year
Wire Feeders & Power Sources.....	3 Year

Upon return of the product, at user's expense, **PROFAX** reserves the right to either repair or replace the product as necessary. This is the only warranty either expressed or implied.

*OMW - Original Manufacturer's Warranty